

Heart to Heart

our way of saying that we view things from our customers perspective. Through this market-oriented approach to doing business, we want to contribute to society.

BIG OIL FLOODED SCREW COMPRESSORS

KOBELION SCREW COMPRESSOR

OIL FLOODED SCREW AIR COMPRESSORS

VS110-160AW
AG110-160AW
XG3900-4730W(V)
110-250kW



KOBE STEEL GROUP Overseas Bases

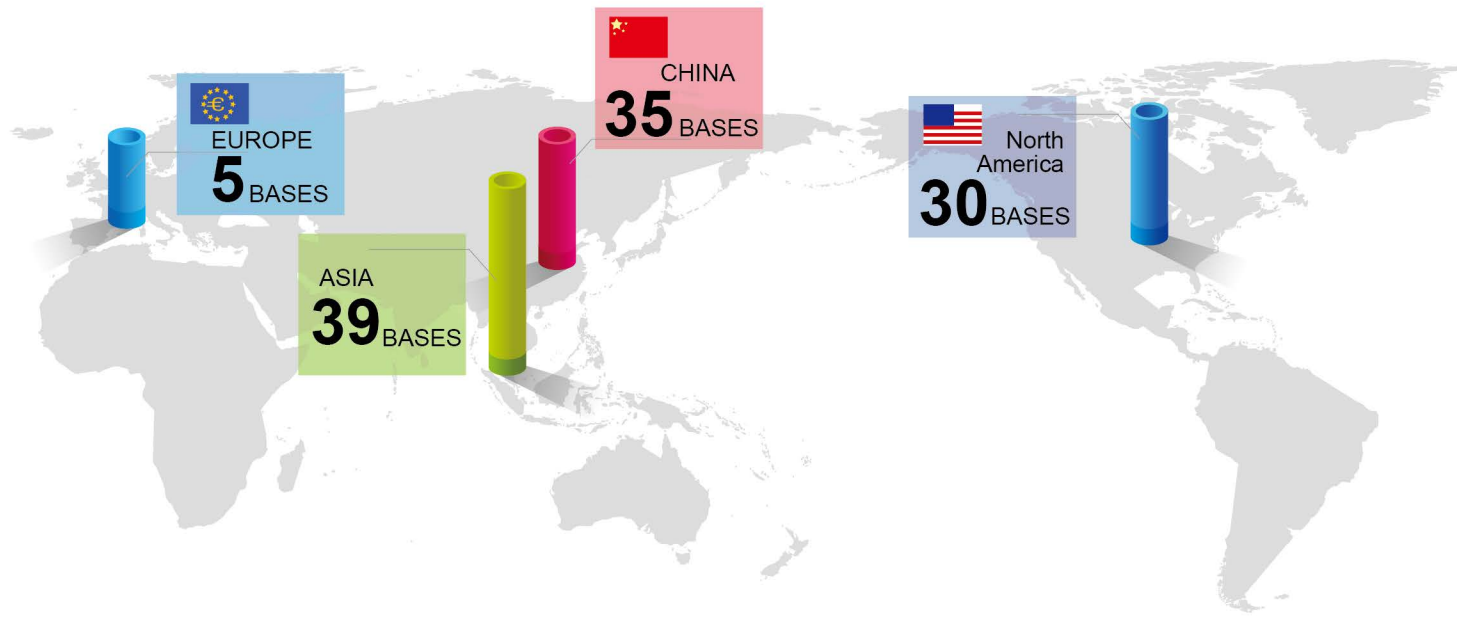

About KOBELCO

KOBELCO is a corporate brand of KOBE STEEL GROUP who is a major steel producer in Japan founded in 1905.

KOBE STEEL adopts diversified farming system and has 8 major business unit, Iron & Steel, Aluminum & Copper, Welding, Machinery, Engineering, Construction Machinery, Mobile Crane, and other business unit like Real Estate.

Each business unit is leading Japanese industry with its 'Only One / Number One' technology.

Now the consolidate subsidiaries are more than 200, and total numbers of employee reaches 35,469 in 03.2012.



Fortune 500 company
Magazine as one of the world's top 500 corporations

Group Name: Kobe Steel, LTD.
Unified Trademark: KOBELCO
Founding Date: Sep.1, 1905



KOBELCO COMPRESSORS DEVELOPMENT HISTORY

About KOBELCO Compressors



Kobelco has a long history of compressors manufacturing and technologies since it produced a high pressure reciprocating compressor for the first time in Japan in 1915. It made Japan's first oil-free screw compressor in 1956. In addition, it began to get involved in the production of centrifugal compressor in 1966, thus becoming one of the world's few comprehensive compressor manufacturers that can produce all piston, screw, centrifugal compressors.

Kobelco, as a material producer, is acquainted with material characteristics and properties, as well as material processing technology. It can develop and produce high efficiency, high performance, high quality products. Its experienced techniques and proven product quality, as well as the eternal pioneer spirit and the pursuit of a more perfect quality make it the industry leader.

Nowadays, Kobelco produces oil-injected and oil-free screw compressors in Japan, US and China and supplies to all over the world.

1915年
1956年
1966年
1988年
1997年
2004年
2014年

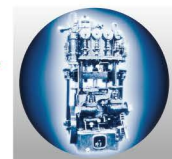

Japan's first high pressure compressor



KOBELION VS-AG SCREW COMPRESSOR



Kobelco factory is certified by ISO9001 Quality management, and ISO14001 Environmental Management.

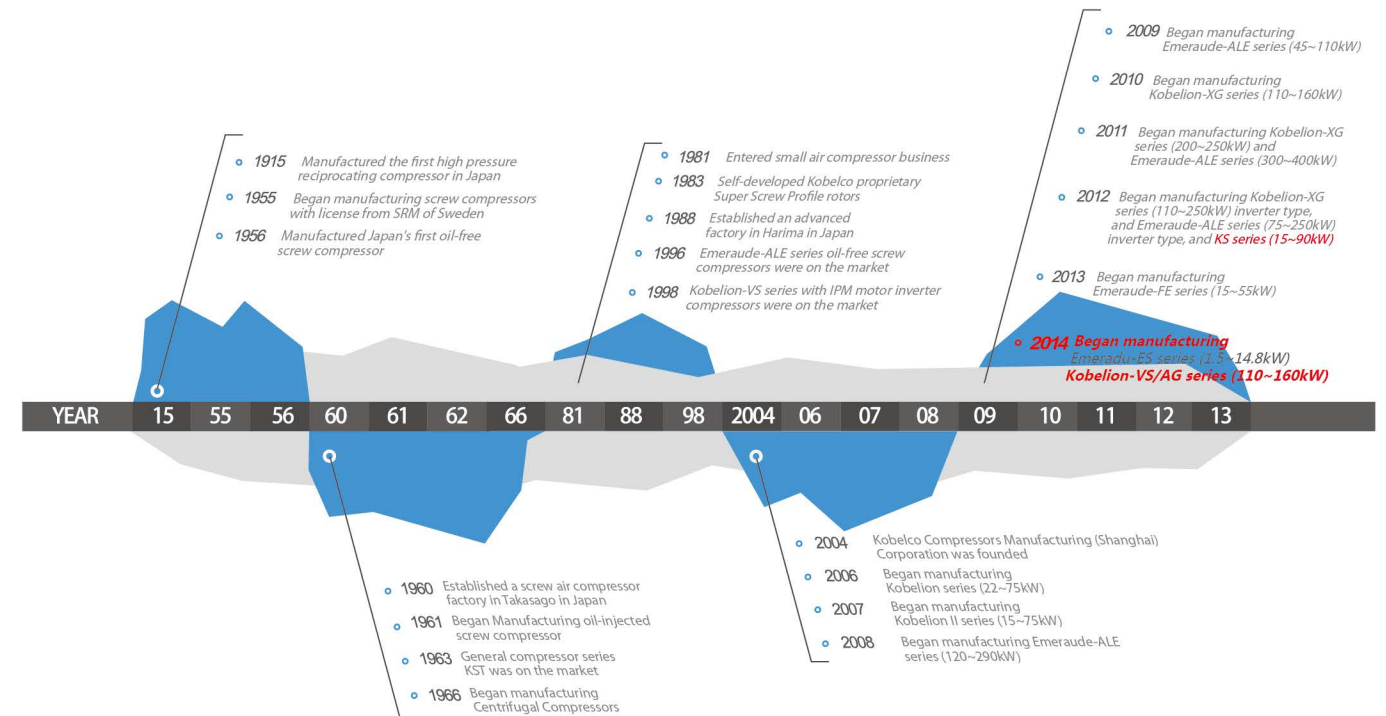



Inherit history and experienced expertise, reach the highest capacity and energy efficiency in the world!

Kobelion series oil flooded screw compressors incorporate Kobelco's half a century's expertise in screw compressor research and manufacture. It takes the highest flow capacity worldwide as the center, and also has both the highest performance and the best quality in the global market.

State-of-the-art Airend from Japan Energy saving

Kobelion series adopts large diameter screw airends made by Kobelco in Japan, to ensure high quality and performance.

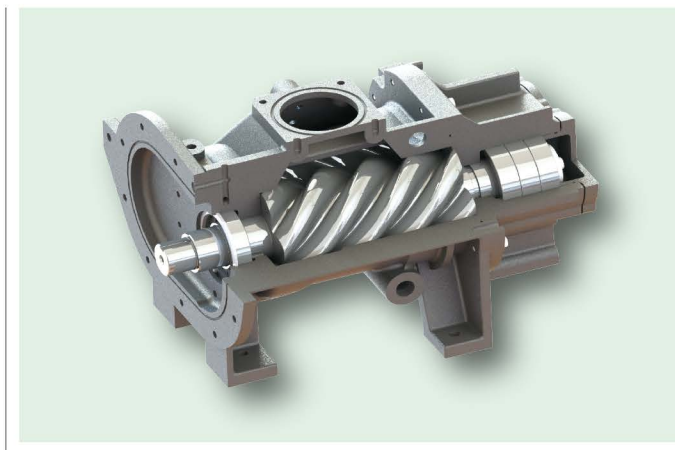

Adapt to harsh ambient temperature Reliability

It has abundant cooling margin and can run safely even at extreme ambient condition.

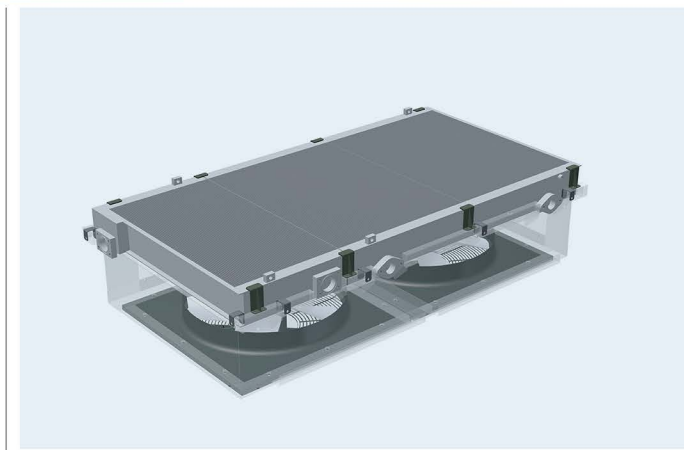

Direct airend drive High performance

It is direct gear driving between airend and motor without coupling, to reduce energy loss.

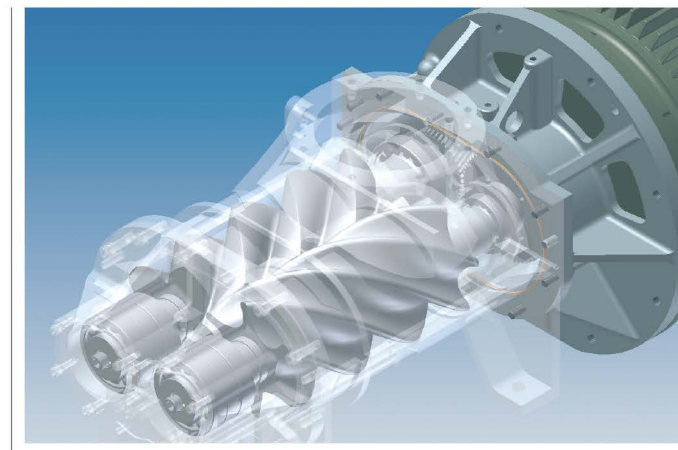

High performance controller Easy to operate

Adopt new touch type liquid crystal display, more easy to operate and time saving. It can coordinate up to 6 units without an additional group controller.



Kobelion is derived from the combination of Kobe Steel Group's trademark "Kobelco" and "Lion".

We select the king of all animals -- the lion, as the series name, because we can provide customers with the newest choices and get their trust.

Proven high reliability isn't a transient glory, but a permanent value beyond era and nations. It represents various beginnings of the prelude to the ballrooms.

- ◀ VS110-160AW
- AG110-160AW
- XG3900-4730W(V)
- 110-250kW

Proven reliable crystal of technology

We have been innovating ceaselessly to provide you with the optimized compressed air solution since it produced Japan's first high pressure piston compressor in 1915.

The highest flow capacity

It adopts big diameter screw airends to offer the highest capacity in the world.

High efficiency and energy saving

This series adopts gear transmission without coupling design in order to reduce energy loss. Kobelco's patent — Energy Saving Logic function.

High reliability

High efficient inlet/outlet systems to ensure adapting to high ambient temperature.

Easy maintenance

Easy for maintaining and long interval period.

Low noise

Lower pulsation noise, improve tone quality.



Inverter driving --The Perfect reflection of high performance and energy saving!

KOBELION VS
SCREW COMPRESSOR

The combination of the most advanced motor technique and inverter technology reflects excellent reliability and energy saving.

Expertise by many years' experience, and dedicated design!

KOBELION AG
SCREW COMPRESSOR

AG series incorporate Kobelco's proven screw compressor technology to ensure high efficiency and reliability.



Adopt optimizing capacity control and constant pressure control to reduce power consumption

VS inverter can adjust rotating speed according to air consumption, with more energy saving as lower loading rate. They can trace the pressure changes quickly and contain the pressure fluctuation in $\pm 0.01\text{MPa}$, supply necessary flow capacity by optimized power.

Inverter control

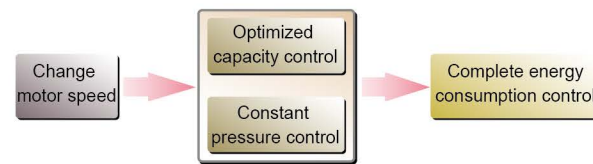

Energy saving by constant pressure control

Pressure fluctuation can be controlled within $\pm 0.01\text{MPa}$.

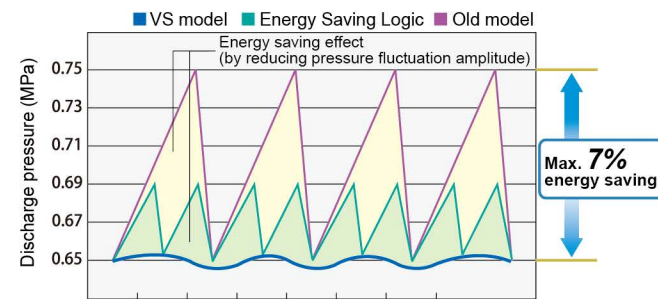

Regulate flow capacity by changing rotating speed

Energy saving characteristics

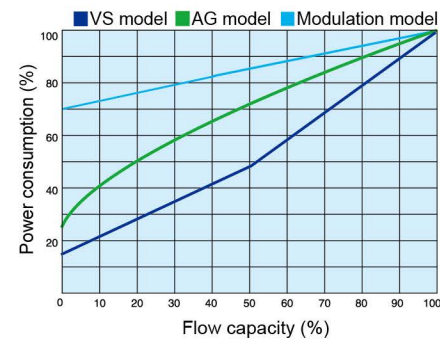

Energy saving example (VS110A compare with standard AG110A)



Calculation conditions:
Running 6000 hours/year. Unit price: 0.15 US\$/kWh. Average loading rate: 60%.

Inverter starter

Reduce starting current and torque to realize steady soft startup, as well as lower electrical devices cost.

Starting current

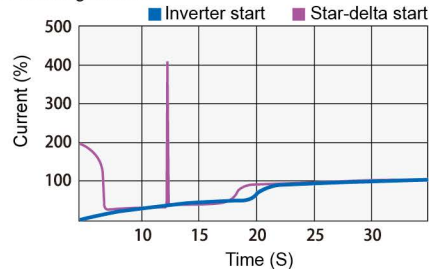

Other characteristics

High frequency reactor is a standard configuration to filter out high frequency harmonics produced by inverter.

Forced cooling on inverter prevents trip at high temperature in summer.

Coating on electronic panel can resist dirt and moisture effectively and enduringly.



Unload regulation reduces energy consumption

AG series adopt unload/load mode which has better energy consumptions efficiency compared to previous modulating mode. In addition, big unloading valves are treated by special oxidized aluminum membrane. It assures steady air supply and energy saving by loading and unloading.

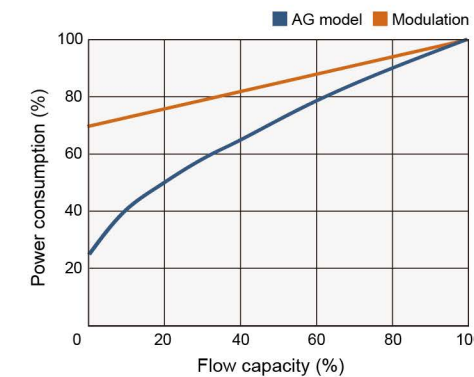

Energy Saving Logic Kobelco Patent

It can unload the compressor in advance if unload/load cycle is longer than setting time (30 seconds). Thus lower pressure fluctuation and eliminate energy consumption caused by unnecessary pressure rise.

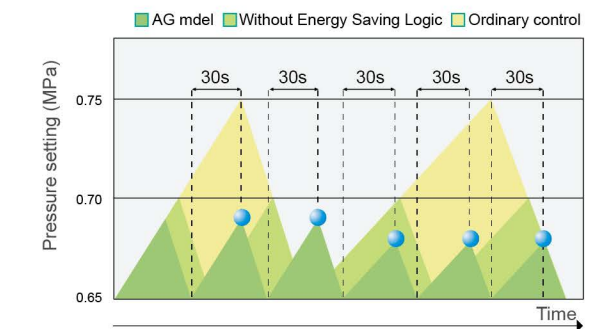

Can start up with certain remaining pressure

It can supply air at certain remaining pressure. It is better than other companies' models which require 1 minute starting delay, to avoid pressure drops beneath lower limit.

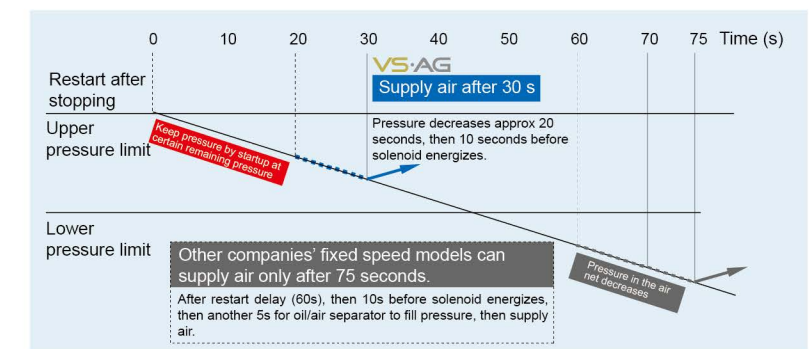

High efficient inlet/outlet systems

Cold/warm cooling air sections and professional air duct design, which consider fully of internal flow pattern and thermal pattern, ensures adaptation to high ambient temperature, as well as reducing noise. It also considers fully of temperature rises around thermal sensitive parts and controller.

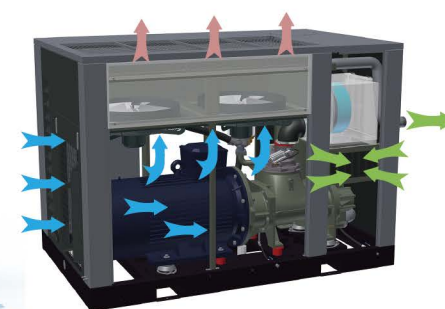

Flow diagram

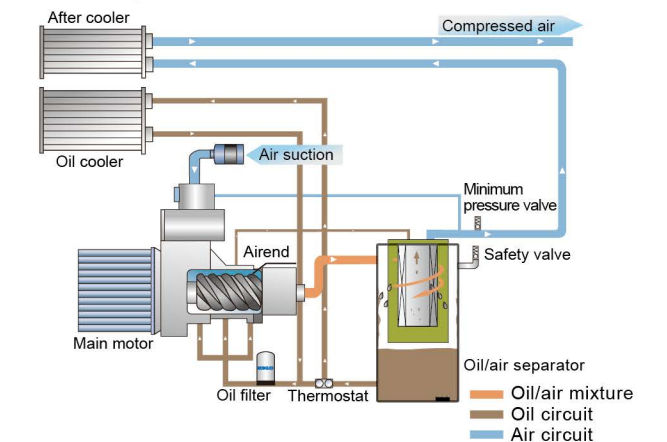

Function Rich Big ITCS Controller



The new liquid crystal electronic controller



New functions

- 7 inches big LCD high resolution screen with background lighting
- Multiple units control
- Standard configured MODBUS module
- USB data download function
- Over current protection
- Flow chart display
- 3 pressure settings
- Many password protections

Standard configured USB data download function

Detailed running data can be stored. Data before and after an accident can be read. Diagnosed data can be available without installing a measuring instrument.



Over current protection

Motor speed will slowdown if inverter detects an over current, in order to continue supply air and prevent emergency shutdown.

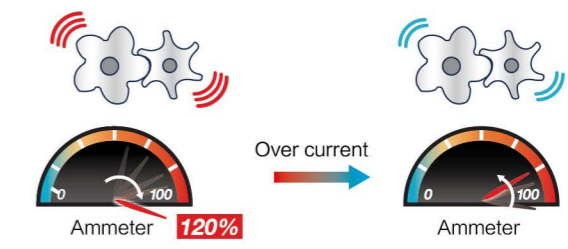

※For VS model only.

Standard configured multiple units control function

Up to 6 units can be coordinated without an additional multiple-units controller, nor is an additional pressure transducer. These compressors can also be group controlled through an additional pressure transducer installed on the air net

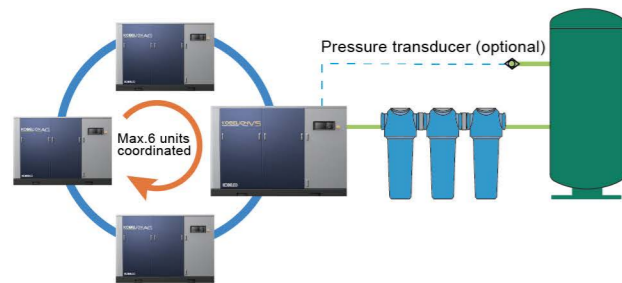

※ Multiple units control function and Modbus function can't be used simultaneously. If you need the two functions simultaneously, please install another multiple-units controller.

Standard configured MODBUS module

MODBUS module is a standard configuration, which can realize Modbus communications that monitor compressors' real time status. It facilitates management and responds to emergencies swiftly.



Other contents displayed

Home page 	Running status 	Pressure setting 	Flow diagram
Maintenance 	Caution 	Emergency 	Log records

- Running status** Many data such as air outlet pressure, pressure in oil separator, loading or unloading, running time, current, inverter consumed current, discharges temperature, temperature of oil separator downstream, ambient temperature, motor coil temperature, air net pressure, etc.
- Maintenance** Up to 30 self-diagnose functions, display maintenance/caution/emergency stop signals timely, and corresponding troubleshooting measures. Facilitate daily inspection/maintenance/management, as well as prevent compressor from breaking suddenly to ensure safe production.
- Weekly timer** There are at most 7 start/stop combination settings in a week. Each combination setting can set different pressures.
- Running data/charts display** Current data display (every 5 seconds).
Operation data display (each hour of the latest 24 hours).
Display contents: discharge pressure, current, loading rate.

Energy saving effect of multiple units controller

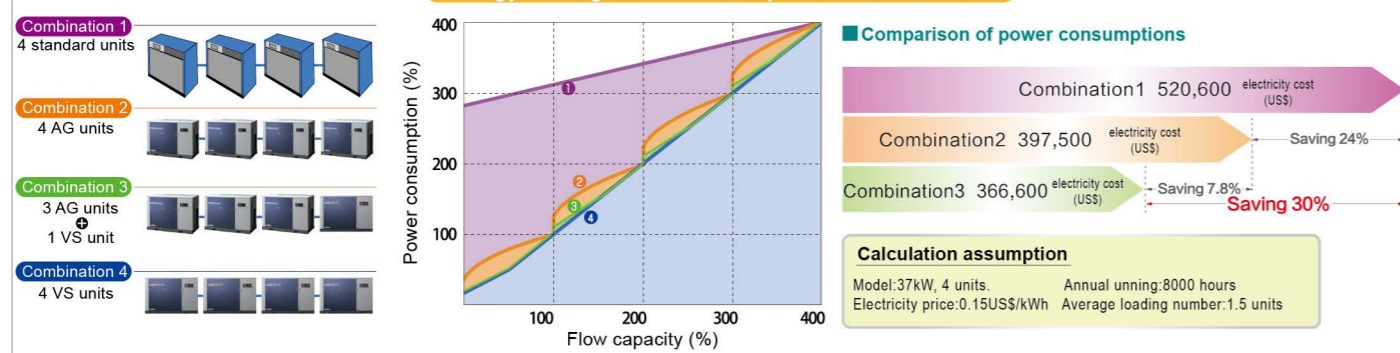



Twin Airends for Energy-saving, Efficiency and Reliability

KOBELION XG
SCREW COMPRESSOR

You have more choices offered by twin Airends for energy-saving, efficiency and reliability.

Pursue the lowest power consumption

XG inverter can adjust rotating speed according to air consumption, greatly reducing unloading consumption. It is the most economical mode.

Energy saving curves

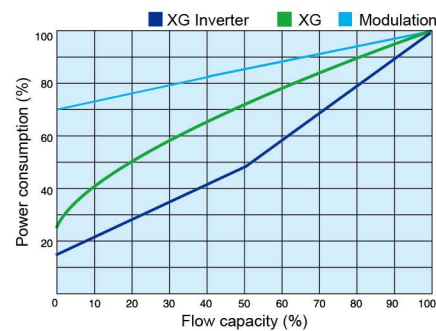

Energy saving by constant pressure control

Pressure fluctuation can be controlled within ± 0.01 MPa by adjusting rotating speed. Reduce energy consumption by unnecessary pressure hikes.

Save 7% energy by, reducing pressure 0.1MPa

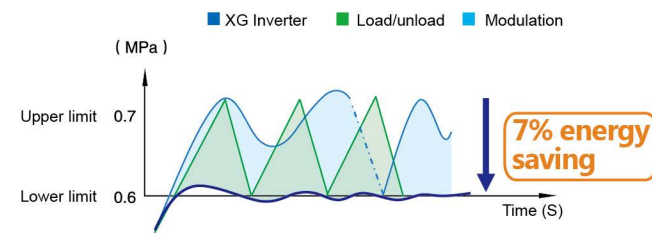

Energy saving effect of inverter

The lifetime cost for air compressor is categorized as electricity consumption, maintenance, machine purchase, labor, etc. Among them 86% is electricity consumption. We can reduce air compressor's lifetime cost by adopting XG inverter series.

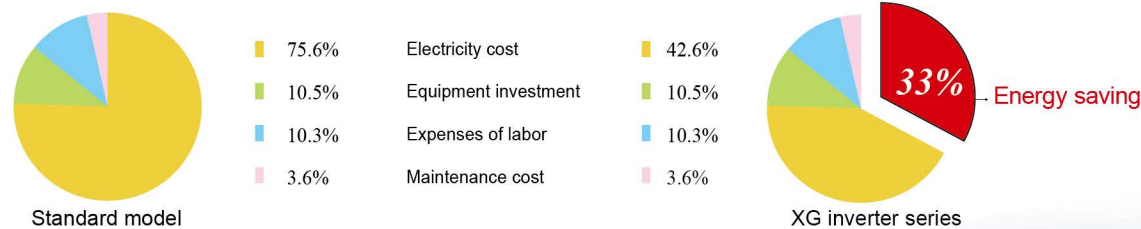

Other advantages

Improve reliability

Inverter's start-up acceleration time can be regulated, in order to reduce moment impact on mechanical parts to improve reliability, and prolong service life. By the way, inverter can eliminate current surge when startup, to protect electrical devices.

Reduce compressor noise

Motor speed slows down in most time, as well as fewer unloading blow-off, effectively decreases noise when compressor is running.



Common features for XG series

Twin airends in parallel

The highest flow capacity and efficiency worldwide. Slow rotor speeds maximize service life for rotating parts and bearings. Lower noise and pulsation.



Coordination of two units

2 units can be coordinated running by simply wiring LCDs. Group controller isn't needed.



Real time display of flow diagram

Add flow diagram display to facilitate knowing running status.

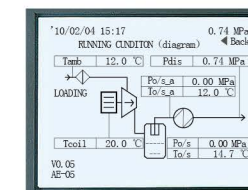

Condensate monitoring

Prevent condensate from accumulation by controlling discharge temperature. It can alert operator to handle it even if condensate occurs.

Self-diagnosis to prevent emergent stop

Know various running conditions by LCD controller, as well as display maintenance, caution and emergency, etc. It can also display corresponding remedy methods in the LCD controller, to deal with emergent matters promptly.

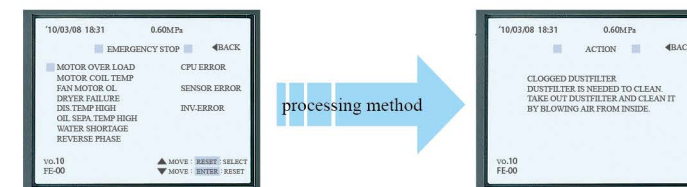

Maintenance	10 items, recommend services for various parts.
Caution	8 items, request check and repair at once.
Emergency	13 items, display corresponding remedy methods in the LCD controller for dealing promptly.

Standard configured Liquid crystal display electronic controller

IP65 protection, high resolution display with LCD background lighting. Chinese, Japanese, English three languages display. It not only monitors running status of compressor, but also sets parameters such as discharge pressure, etc. It can also record operation, display chart, set time weekly, manage daily and weekly information.

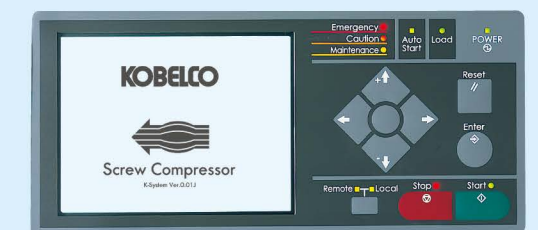



Elaborate Design of Details

KOBELIONVS·AG·XG
SCREW COMPRESSOR



High efficient coolers

Oil cooler and after cooler are separated to not only improve efficiency, but also avoid damaging coolers due to different temperatures, so as to prolong their lifetimes.



KOBELCO TOUGH GREASE

Adopt Kobelco's exclusive TOUGH grease to improve motor efficiency by 2%, as well as ensure more stable running because its long service interval and high temperature endurance.
※ For VS/AG model only.



High efficient motors

Insulation class F, protection class IP55 total enclosure effectively prevents dust and water from entering motor. In addition, it is standard configured with Phase Sequence Relay to prevent motor from rotating reversely, in order to protect units. It also embeds a thermocouple to detect motor coil's temperature to protect motor.



Low noise

Adopt advanced new FEM analysis, new designed structure, optimized muffle material, etc. to achieve super low running noise. Consider fully of sound pressure/sound tone/sound volume by adding insulation boards and air duct etc, to reduce noise that it is the lowest in its category.

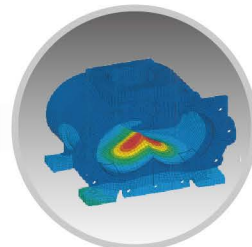

Draw out water cooler bundles

Internal bundles of oil cooler and after cooler can be drawn out for convenient cleaning and servicing if they are clogged.



Adopt big high efficient air inlet filters

Adopt big air inlet filters to reduce pressure loss and prolong cleaning interval, in order to cope with dusty environment. Centrifugal + filtration: 2 steps separation. ISO Fine TD 99.98%.

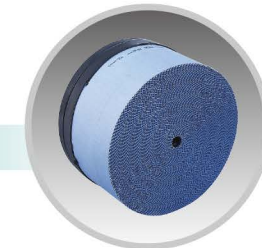

High efficient oil filter

Adopt big oil filter with high separating efficiency to ensure clean oil, as well as prolong oil and related parts' service lifetimes.



Oil separator

Reduce remaining oil in the outlet air to less than 2 ppm by 3 steps high efficient oil separation: centrifugal force, gravity, and filtration.

- 1st step: Centrifugal force**
The mixture of compressed air and oil from airoend rotates in the oil separator, oil is separated by centrifugal force.
- 2nd step: Gravity**
The oil which is separated by centrifugal force to the inner wall flows down to the bottom by gravity. There are several magnets at the bottom of the separator to filter out metal scraps in the air stream, in order not to scratch the separating element.
- 3rd step: Filtration**
Adopt big separating elements to suit its flow capacity. The cylindrical separating element is mainly composed of fiber, to filter out the remaining oil mist.



Perfect electrical protections

- ◆ Setting for transient electricity outage...within 0.3 sec. The compressor doesn't stop if electricity outage is within the setting time. The compressor will stop only when electricity outage exceeds the setting time. (For AG it is 0.2 sec.)
- ◆ Setting for automatic restart after electricity outage...1~20sec. (Example as right) Resuming electricity is set at 5 sec, delay setting is 15 sec. after electricity resumes.
- ◆ Built-in 7,500V surge protector and noise filter. (XG model is 12,000V)

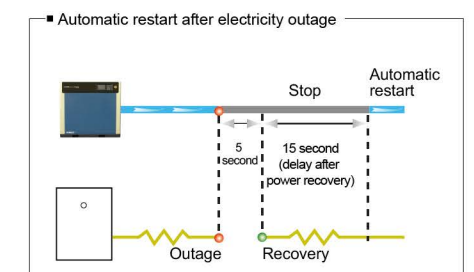
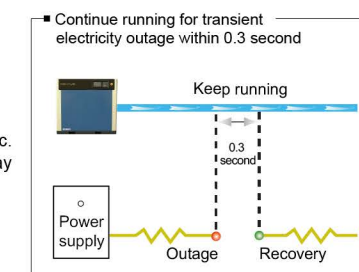

Specifications

Provide a full range of services

VS/XG Inverter Series

Model	Max. pressure (MPa)	Flow capacity (m³/min)	Main motor power (kW)	Outlet connection diameter	Noise dB(A)	Dimensions (mm)			Weight (kg)
						Length	Width	Height	
VS110AW	0.75	21.4	110	R ₂ 3/DN80Flange	69	2,600	1,600	1,850	3,000(2,900)*
VS132AW		25.4	132	R ₂ 3/DN80Flange	70	2,600	1,600	1,850	3,250(3,050)
VS160AW		30.3	160	R ₂ 3/DN80Flange	71	2,600	1,600	1,850	3,600(3,250)
XG3900WV-200		39.0	200	R ₂ 4/DN100Flange	75	3,060	2,120	2,150	5,240
XG4730WV-250		47.3	250	R ₂ 4/DN100Flange	75	3,060	2,120	2,150	5,650
VS110AW-H	0.85	20.2	110	R ₂ 3/DN80Flange	69	2,600	1,600	1,850	3,000(2,900)
VS132AW-H		24.1	132	R ₂ 3/DN80Flange	70	2,600	1,600	1,850	3,250(3,050)
VS160AW-H		28.8	160	R ₂ 3/DN80Flange	71	2,600	1,600	1,850	3,600(3,250)
XG3900WV-200H		36.6	200	R ₂ 4/DN100Flange	75	3,060	2,120	2,150	5,240
XG4730WV-250H		44.1	250	R ₂ 4/DN100Flange	75	3,060	2,120	2,150	5,650
VS110AW-GH	1.0	18.6	110	R ₂ 3/DN80Flange	69	2,600	1,600	1,850	3,000 (2,900)
VS132AW-GH		21.4	132	R ₂ 3/DN80Flange	70	2,600	1,600	1,850	3,250 (3,050)
VS160AW-GH		23.8	160	R ₂ 3/DN80Flange	71	2,600	1,600	1,850	3,500 (3,150)

AG/XG Series

Model	Max. pressure (MPa)	Flow capacity (m³/min)	Main motor power (kW)	Outlet connection diameter	Noise dB(A)	Dimensions (mm)			Weight (kg)
						Length	Width	Height	
AG110AW	0.75	21.4	110	R ₂ 3/DN80Flange	69	2,600	1,600	1,850	2,950(2,850)
AG132AW		25.4	132	R ₂ 3/DN80Flange	70	2,600	1,600	1,850	3,150(2,950)
AG160AW		30.3	160	R ₂ 3/DN80Flange	71	2,600	1,600	1,850	3,500(3,150)
XG3900W-200		39.0	200	R ₂ 4/DN100Flange	75	3,060	2,120	2,150	5,020
XG3900W-200T		39.0	200	R ₂ 4/DN100Flange	75	3,060	2,120	2,150	6,120
XG4730W-250	0.85	47.3	250	R ₂ 4/DN100Flange	75	3,060	2,120	2,150	5,430
XG4730W-250T		47.3	250	R ₂ 4/DN100Flange	75	3,060	2,120	2,150	6,320
AG110AW-H		20.2	110	R ₂ 3/DN80Flange	69	2,600	1,600	1,850	2,950(2,850)
AG132AW-H		24.1	132	R ₂ 3/DN80Flange	70	2,600	1,600	1,850	3,150(2,950)
AG160AW-H		28.8	160	R ₂ 3/DN80Flange	71	2,600	1,600	1,850	3,500(3,150)
XG3900W-200H	1.0	36.6	200	R ₂ 4/DN100Flange	75	3,060	2,120	2,150	5,020
XG3900W-200HT		36.6	200	R ₂ 4/DN100Flange	75	3,060	2,120	2,150	6,120
XG4730W-250H		44.1	250	R ₂ 4/DN100Flange	75	3,060	2,120	2,150	5,430
XG4730W-250HT		44.1	250	R ₂ 4/DN100Flange	75	3,060	2,120	2,150	6,320
AG110AW-GH		18.6	110	R ₂ 3/DN80Flange	69	2,600	1,600	1,850	2,950(2,850)
AG132AW-GH	21.4	132	R ₂ 3/DN80Flange	70	2,600	1,600	1,850	3,150(2,950)	
AG160AW-GH	25.8	160	R ₂ 3/DN80Flange	71	2,600	1,600	1,850	3,500(3,150)	
XG3900W-200GH	1.0	35.3	200	R ₂ 4/DN100Flange	75	3,060	2,120	2,150	5,020
XG3900W-200GHT		35.3	200	R ₂ 4/DN100Flange	75	3,060	2,120	2,150	6,120
XG4730W-250GH		40.7	250	R ₂ 4/DN100Flange	75	3,060	2,120	2,150	5,430
XG4730W-250GHT	40.7	250	R ₂ 4/DN100Flange	75	3,060	2,120	2,150	6,320	

* Water-cooled models' data in ()
For details please look "Specification Manual".

Model name explanation

VS 110 A- H XG 3900 W V- 200 H T

Series name	Main motor power	Cooling method	Discharge pressure	Series name	Capacity	Cooling method	Starting way	Main motor power	Discharge pressure	Voltage
VS	110~160kW	A : Air cooled	No: 0.75MPa H: 0.85MPa GH: 1.05MPa	XG	39.0m³/min 47.3m³/min	W: Water cooled	No: Star-delta V: Inverter	200~250kW	No: 0.75MPa H: 0.85MPa GH: 1.0MPa	No: 380V T: 10KV

■ Notes:
Power supply: 380V/50Hz/3 phases 3 lines Flow capacity: Convert the outlet flow to the air inlet conditions Air inlet conditions: 1 bar, 20 C, 0%

KOBELCO NET WORK

Kobelco has set up a sales/service network around the world to meet customers' requirement more perfectly. It can provide various services from daily technique support to technology proposals.

Our sales and service staff carefully listen to customers' opinions, and transfer them to technology departments to guide development of Kobelco's compressors. We will ceaselessly strive to provide customers with the most suitable and the highest quality compressors.

